

# 1200V 75A Insulated Gate Bipolar Transistor

## AKBK2A075YHH

### Description:

Gen 2 IGBT with soft, fast recovery full current rated anti-parallel Emitter Controlled diode, providing ultra-low conduction loss . They are designed for applications such as UPS, inverters, etc.

### Features:

- 10μsec short circuit withstand time at  $T_{VJ}=175^{\circ}\text{C}$
- Easy paralleling capability due to positive temperature coefficient in  $V_{CEsat}$
- Low EMI
- Low Gate Charge  $Q_G$
- Very soft, fast recovery full current anti-parallel diode
- Maximum junction temperature  $T_{VJMAX}=175^{\circ}\text{C}$
- RoHS compliant <sup>(Note 1)</sup>
- Halogen-free <sup>(Note 1)</sup>

### Applications:

- Industrial UPS
- Charger
- Energy Storage
- Three-phase Solar String Inverter

### Key Performance Parameters:

Parameter	Value	Unit
$V_{CE}$	1200	V
$V_{CESAT}, T_{VJ} = 25^{\circ}\text{C}$	1.9	V
$I_C$	75	A

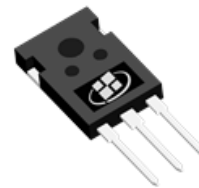

TO247Plus

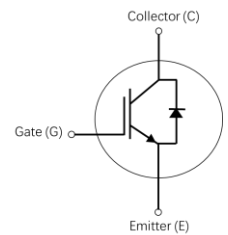

### Ordering Information:

Ordering Code	Package Type	Marking Code	Form	Packing
AKBK2A075YHH	TO247Plus-3L	BK2A075YHH	Tube	300PCS

### Notes:

1. Contact ALKAIDSEMI sales for detail information

## Maximum Ratings (T<sub>VJ</sub> = 25°C unless otherwise noted)

Symbol	Parameter	Value	Units
V <sub>CE</sub>	Collector- Emitter Voltage	1200	V
I <sub>C</sub>	Collector Current - Continuous (T <sub>C</sub> = 25°C) <sup>(Note 1)</sup>	150	A
	Collector Current - Continuous (T <sub>C</sub> = 100°C)	75	A
I <sub>CM</sub>	Collector Current - Pulsed <sup>(Note 2)</sup>	300	A
I <sub>F</sub>	Diode Forward Current, Limited by T <sub>VJmax</sub> (T <sub>C</sub> = 25°C)	150	A
	Diode Forward Current, Limited by T <sub>VJmax</sub> (T <sub>C</sub> = 100°C)	75	A
I <sub>FM</sub>	Diode Pulsed Current, - Pulsed <sup>(Note 2)</sup>	300	A
V <sub>GE</sub>	Gate-Emitter Voltage	±20	V
	Transient Gate-Emitter Voltage (tp ≤ 10µs, D < 0.010)	±30	
T <sub>SC</sub>	Short Circuit Withstand Time V <sub>GE</sub> = 15.0V, V <sub>CC</sub> ≤ 400V	10	µs
P <sub>D</sub>	Power Dissipation (T <sub>C</sub> = 25°C)	937	W
	Power Dissipation (T <sub>C</sub> = 100°C)	468	W
T <sub>VJ</sub>	Operating Junction Temperature Range	-40 to +175	°C
T <sub>STG</sub>	Storage Temperature Range	-55 to +150	°C

## Thermal Characteristics

Symbol	Parameter	Value	Units
R <sub>θJC</sub>	IGBT Thermal Resistance, Junction-to-Case, Steady-State	0.16	°C/W
R <sub>θJC</sub>	Diode Thermal Resistance, Junction-to-Case, Steady-State	0.28	°C/W
R <sub>θJA</sub>	Thermal Resistance, Junction-to-Ambient Steady State	40	°C/W

### Notes:

1. The max collector current rating is package limited
2. Repetitive Rating: Pulse width limited by maximum junction temperature

<b>Electrical Characteristics</b> ( $T_{VJ} = 25^{\circ}\text{C}$ unless otherwise noted)						
Symbol	Parameter	Test Conditions	Min	Typ	Max	Units
<b>Static Characteristics</b>						
$V_{(BR)CES}$	Collector-Emitter Breakdown Voltage	$V_{GE} = 0\text{ V}, I_C = 1\text{ mA}$	1200			V
$V_{CESAT}$	Collector-Emitter Saturation Voltage	$V_{GE} = 15\text{ V}, I_C = 75\text{ A}$	1.7	1.9	2.3	V
		$V_{GE} = 15\text{ V}, I_C = 75\text{ A}, T_{VJ} = 175^{\circ}\text{C}$		2.8		
$V_F$	Diode Forward Voltage	$V_{GE} = 0\text{ V}, I_F = 75\text{ A}$	1.7	1.8	2.3	V
		$V_{GE} = 0\text{ V}, I_F = 75\text{ A}, T_{VJ} = 175^{\circ}\text{C}$		1.85		
$V_{GE(th)}$	Gate-Emitter Threshold Voltage	$V_{CE} = V_{GE}, I_C = 2.6\text{ mA}$	5.1	5.8	6.5	V
$I_{CES}$	Zero Gate Voltage Collector Current	$V_{CE} = 1200\text{ V}, V_{GE} = 0\text{ V}$			450	$\mu\text{A}$
		$V_{CE} = 1200\text{ V}, V_{GE} = 0\text{ V}, T_{VJ} = 175^{\circ}\text{C}$		5000		
$I_{GES}$	Gate-Emitter Leakage Current	$V_{GE} = \pm 20\text{ V}, V_{CE} = 0\text{ V}$			$\pm 100$	nA
$g_{fs}$	Transconductance	$V_{GE} = 20\text{ V}, I_C = 75\text{ A}$		49		S
<b>Dynamic Characteristics</b>						
$C_{ies}$	Input Capacitance	$V_{CE} = 25\text{ V}, V_{GE} = 0\text{ V},$ $F = 1\text{ MHz}$		9812		pF
$C_{oes}$	Output Capacitance			312		pF
$C_{res}$	Reverse Transfer Capacitance			61		pF
$Q_G$	Total Gate Charge	$V_{CC} = 960\text{ V}, I_C = 75\text{ A},$ $V_{GE} = 15\text{ V}$		321		nC
$Q_{GE}$	Gate-Emitter Charge			71		nC
$Q_{GC}$	Gate-Collector Charge			121		nC
$L_E$	Internal Emitter Inductance			8		nH
<b>Switching Characteristics, Inductive Load</b> ( $T_{VJ} = 25^{\circ}\text{C}$ )						
$t_{d(on)}$	Turn On Delay Time	$V_{CC} = 600\text{ V}$ $I_C = 75\text{ A}$ $V_{GE} = 15\text{ V}$ $R_{G(on)} = 6\ \Omega$ $R_{G(off)} = 6\ \Omega$		46		ns
$t_r$	Rise Time			60		ns
$t_{d(off)}$	Turn Off Delay Time			185		ns
$t_f$	Fall Time			89		ns
$E_{on}$	Turn On Energy			5.69		mJ
$E_{off}$	Turn Off Energy			2.75		mJ
$E_{total}$	Total Switching Energy			8.44		mJ

Diode Characteristics						
$t_{rr}$	Reverse Recovery Time	$V_{CC} = 600\text{ V}$ , $I_F = 75\text{ A}$ , $di/dt = 600\text{ A}/\mu\text{s}$		394		ns
$Q_{RR}$	Reverse Recovery Charge			2.9		$\mu\text{C}$
$I_{rrm}$	Peak Reverse Recovery Current			14		A
$d_{irr}/dt$	Diode Peak Rate of Fall of Reverse Recovery Current			-32		$\text{A}/\mu\text{s}$

### Switching Characteristics, Inductive Load ( $T_{VJ} = 175^\circ\text{C}$ )

$t_{d(on)}$	Turn On Delay Time	$V_{CC} = 600\text{ V}$ $I_C = 75\text{ A}$ $V_{GE} = 15\text{ V}$ $R_{G(on)} = 6\ \Omega$ $R_{G(off)} = 6\ \Omega$		45		ns
$t_r$	Rise Time			70		ns
$t_{d(off)}$	Turn Off Delay Time			208		ns
$t_f$	Fall Time			149		ns
$E_{on}$	Turn On Energy			9.87		mJ
$E_{off}$	Turn Off Energy			4.04		mJ
$E_{total}$	Total Switching Energy			13.92		mJ

### Diode Characteristics

$t_{rr}$	Reverse Recovery Time	$V_R = 600\text{ V}$ , $I_F = 75\text{ A}$ , $di/dt = 600\text{ A}/\mu\text{s}$		541		ns
$Q_{RR}$	Reverse Recovery Charge			10		$\mu\text{C}$
$I_{rrm}$	Peak Reverse Recovery Current			28.9		A
$d_{irr}/dt$	Diode Peak Rate of Fall of Reverse Recovery Current			-95		$\text{A}/\mu\text{s}$

# Electrical Characteristics Diagrams

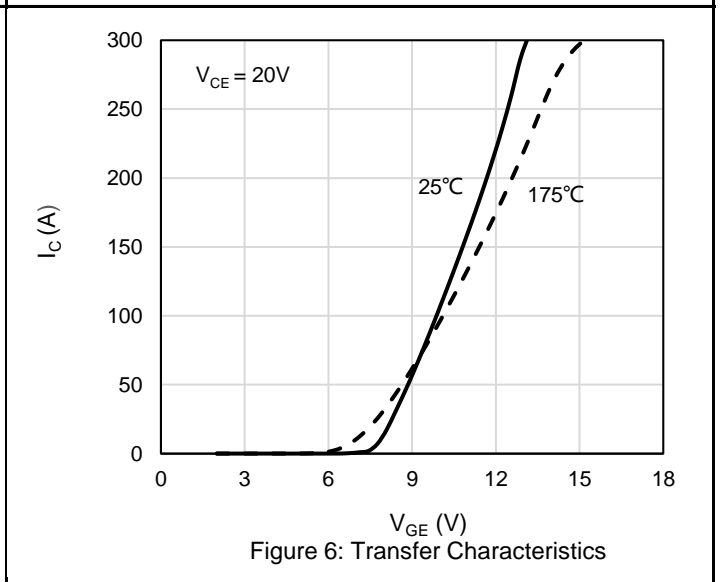
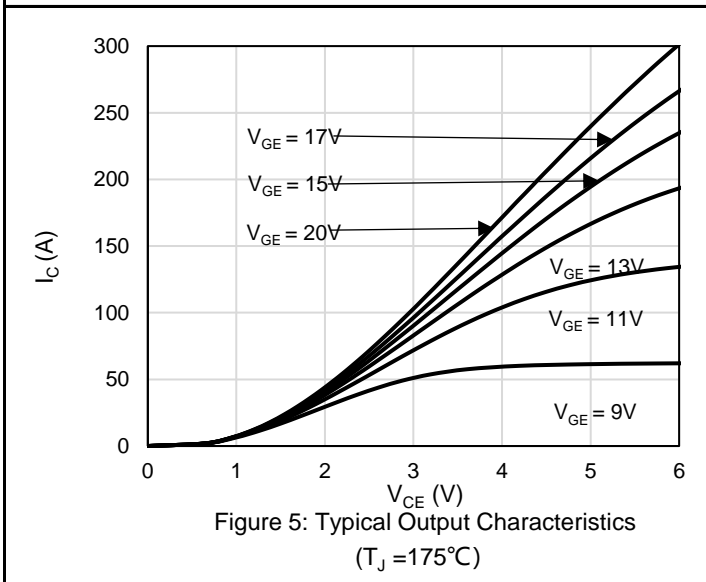
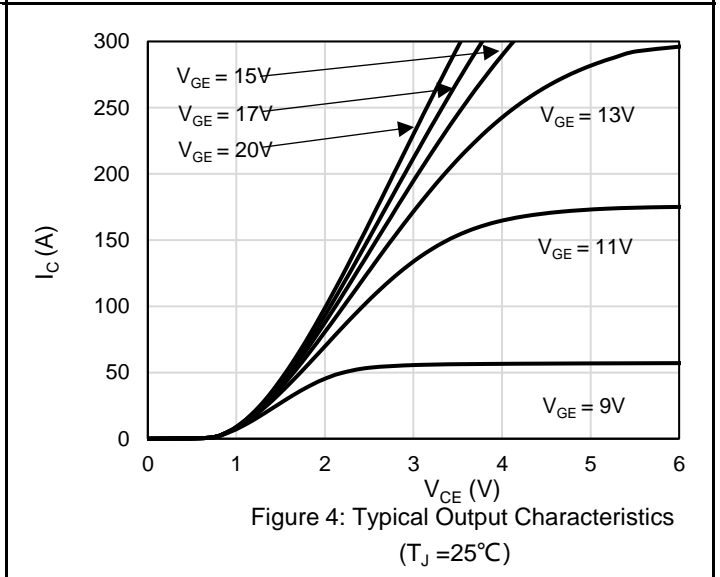
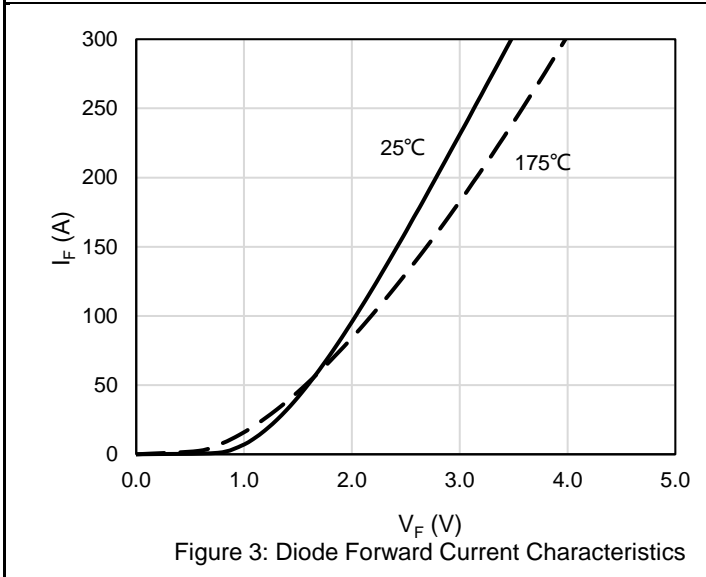
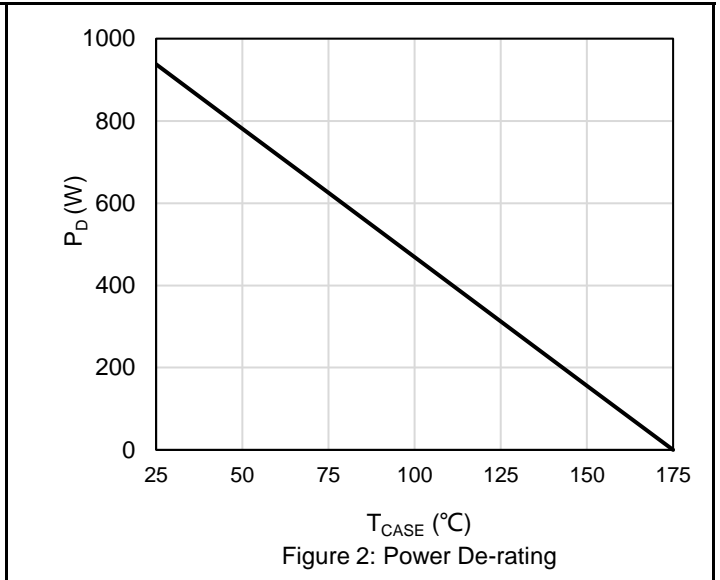
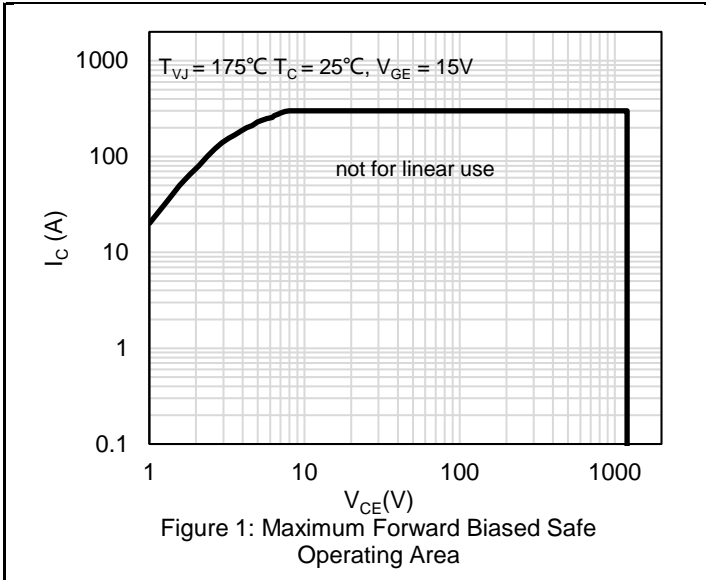

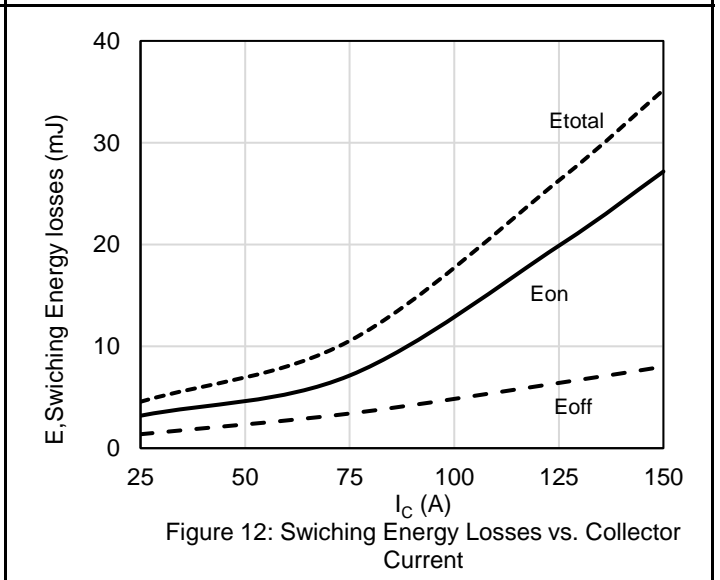
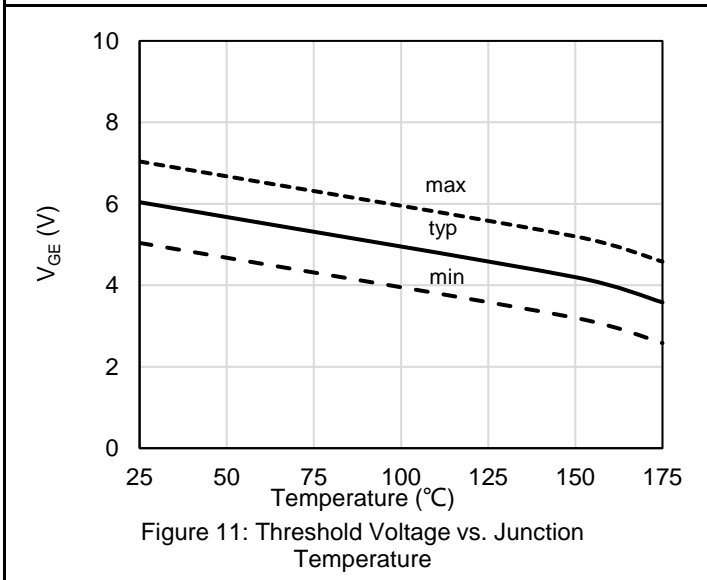
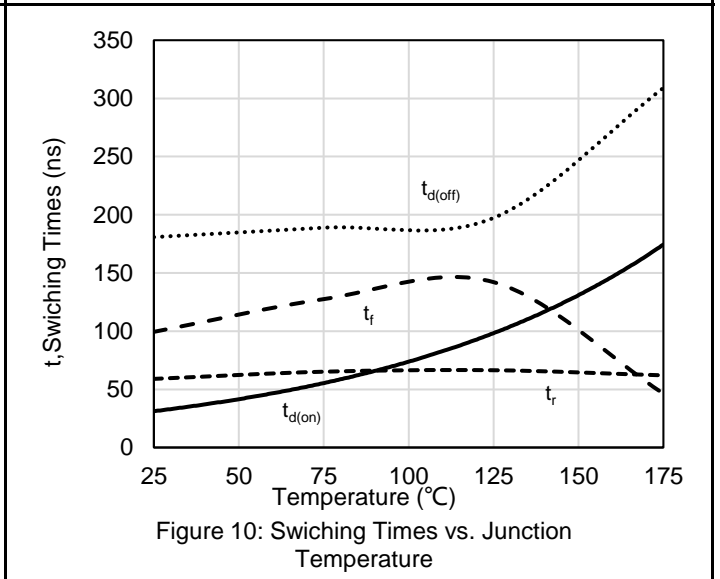
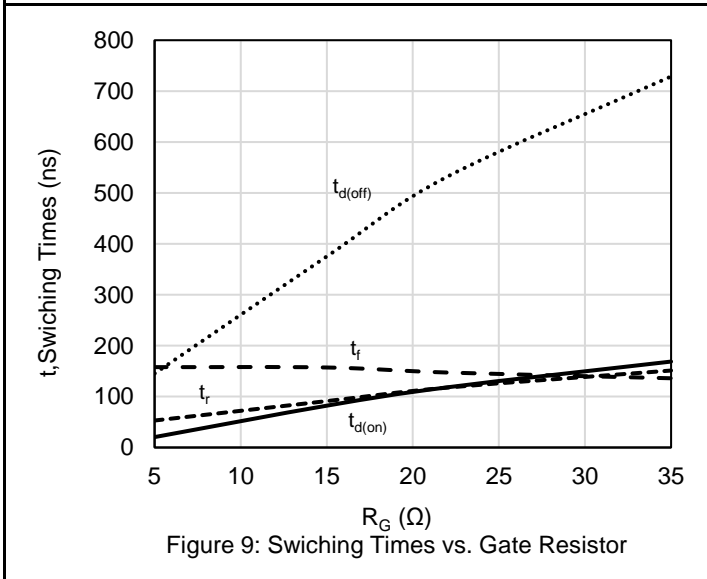
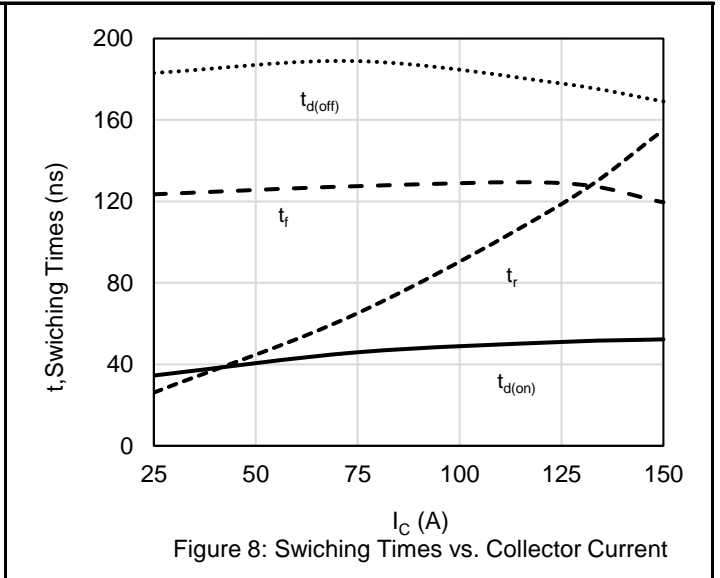
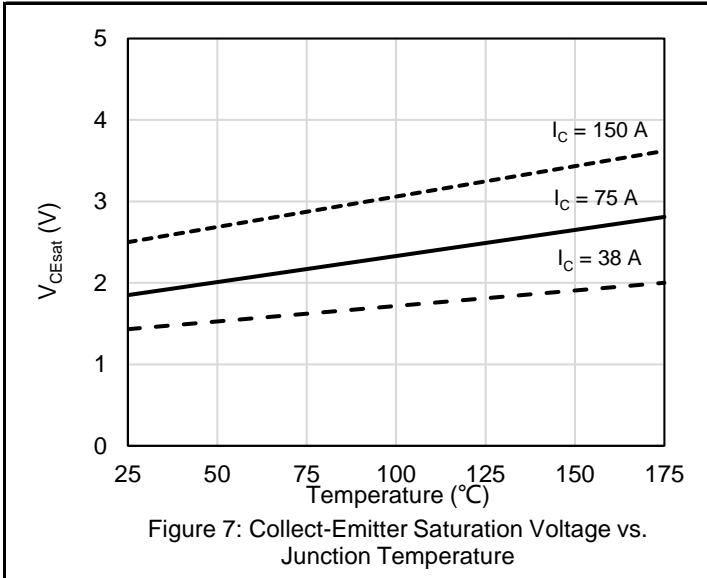

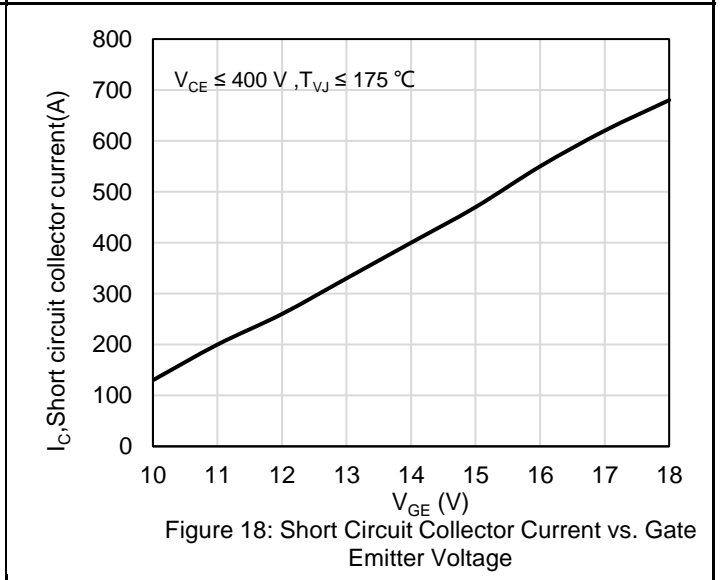
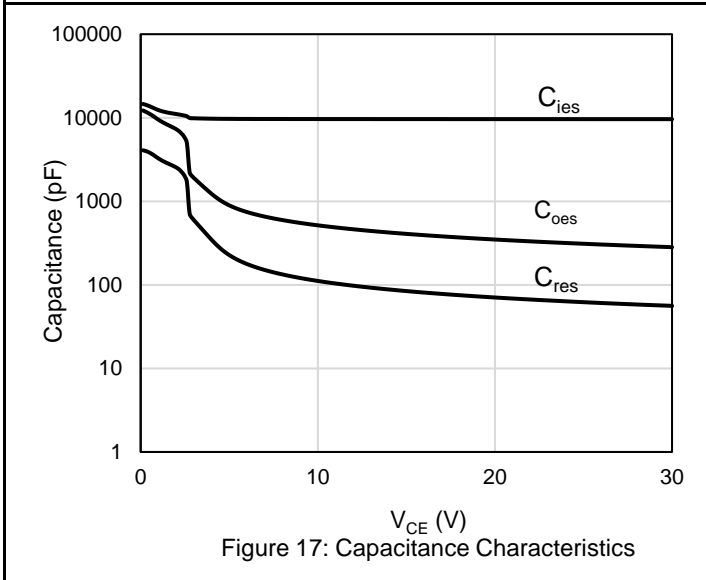
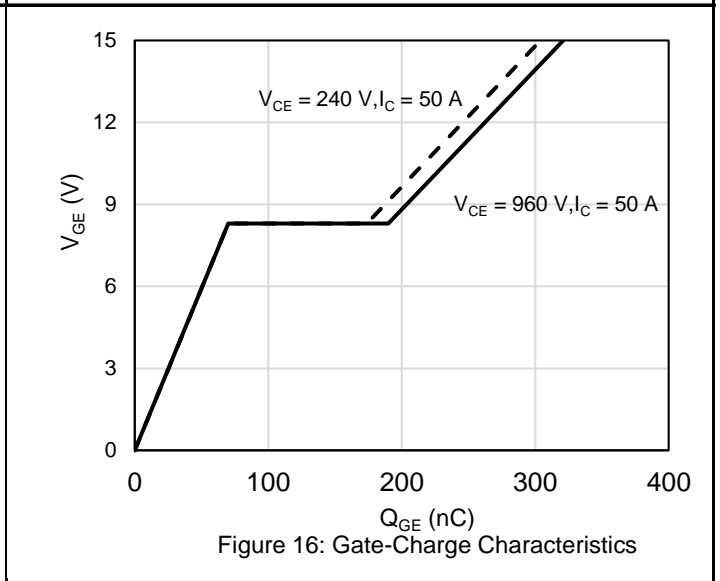
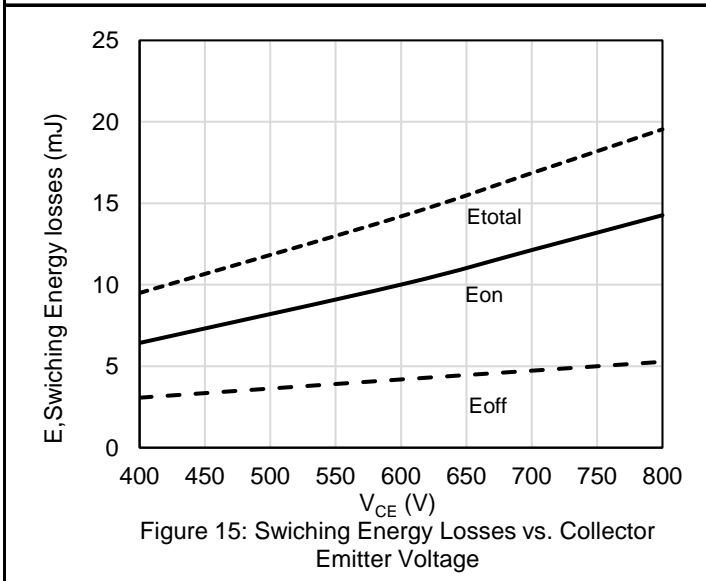
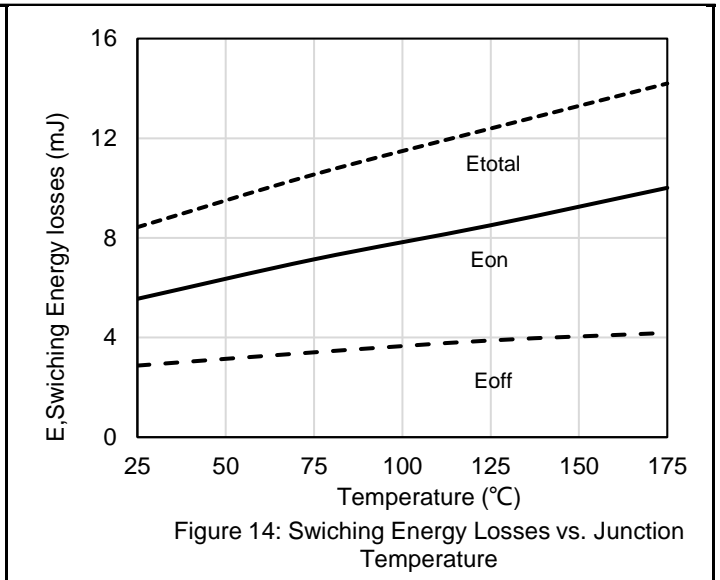
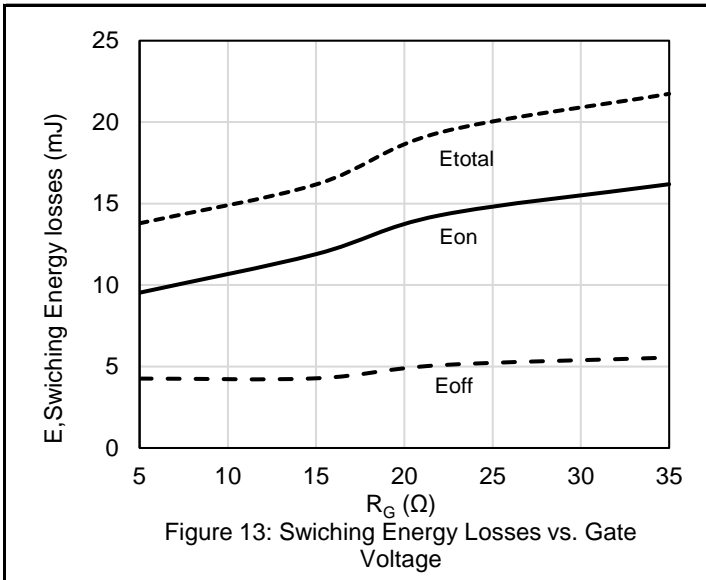

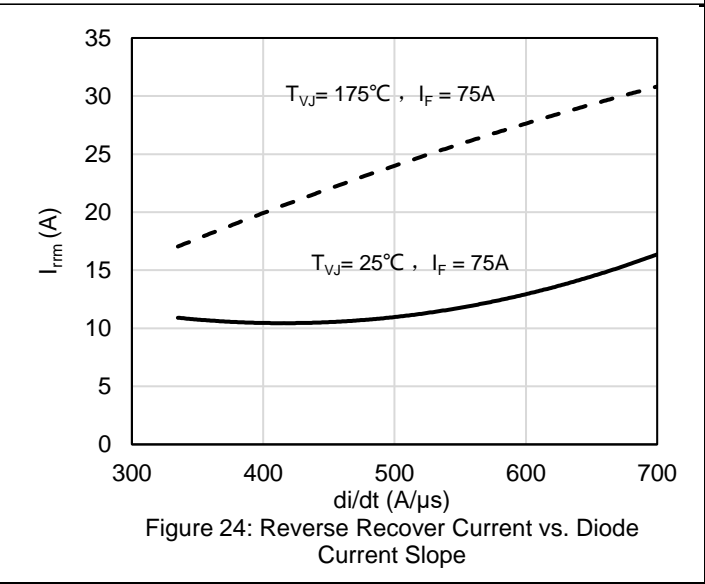
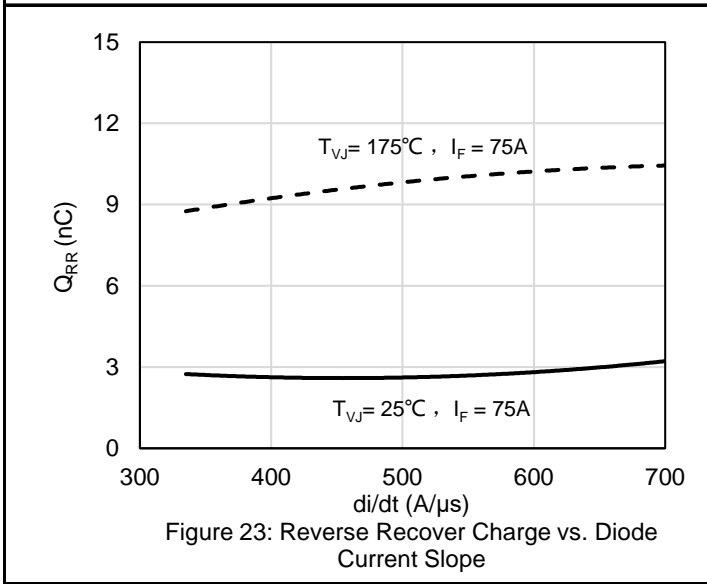
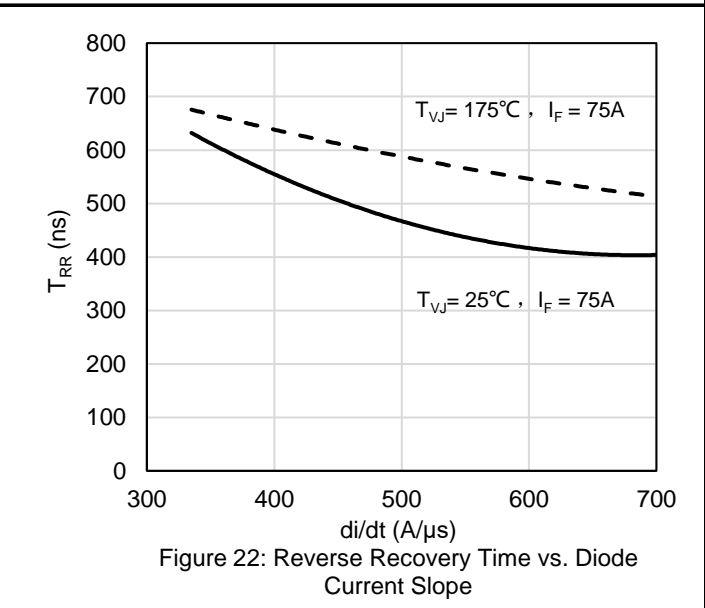
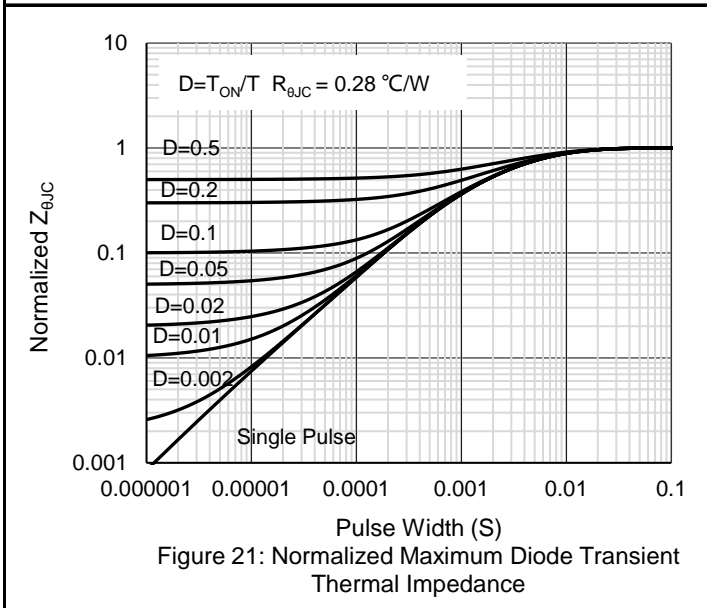
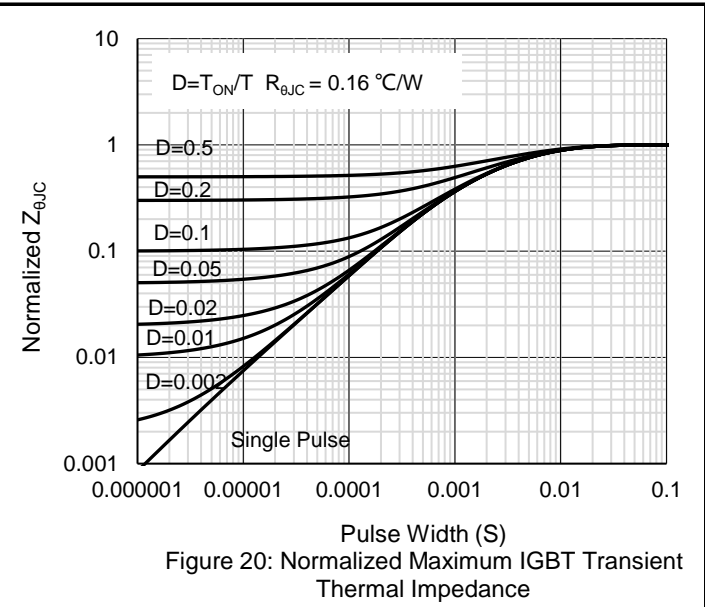
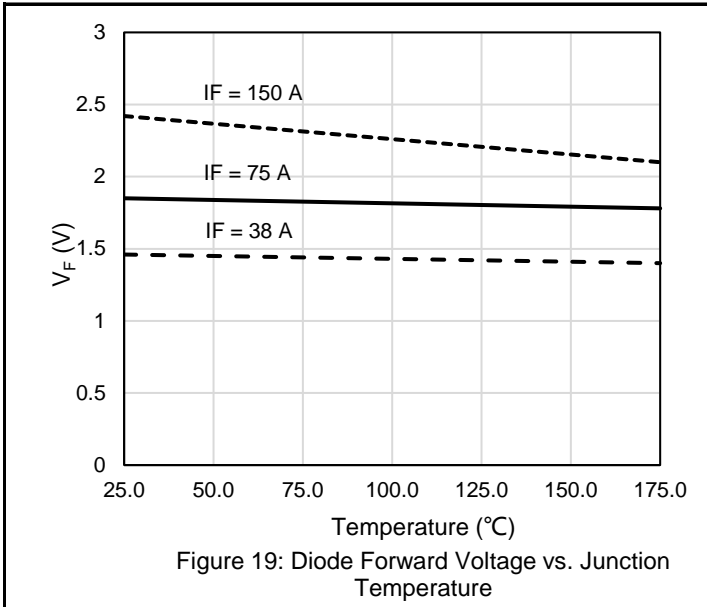



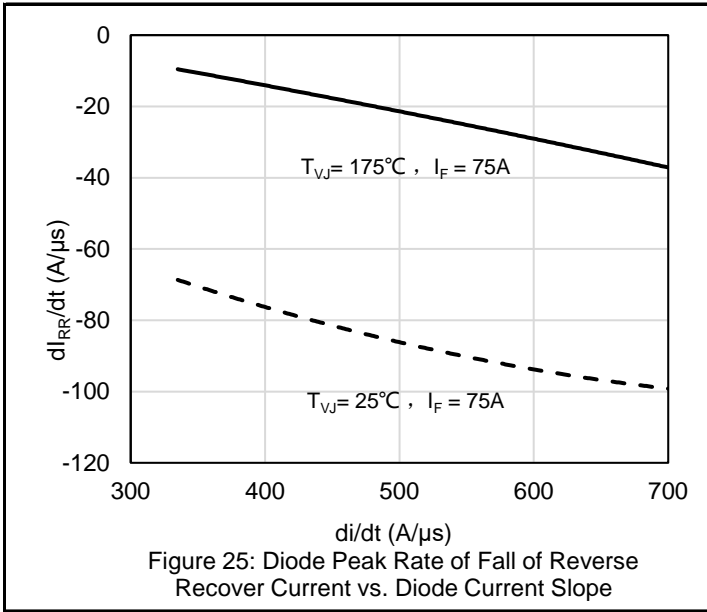

# Test Circuit and Waveform

## Switching Test Circuit & Waveforms

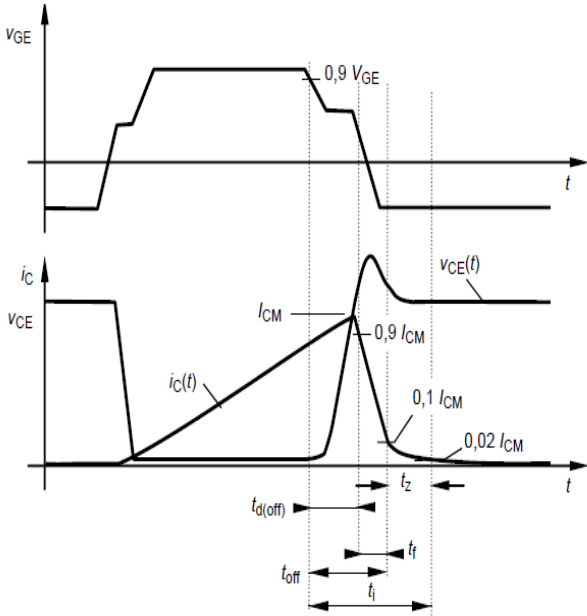

## Diode Recovery Test Circuit & Waveforms

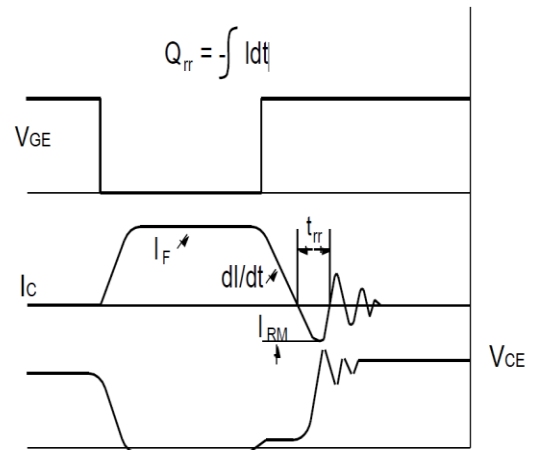
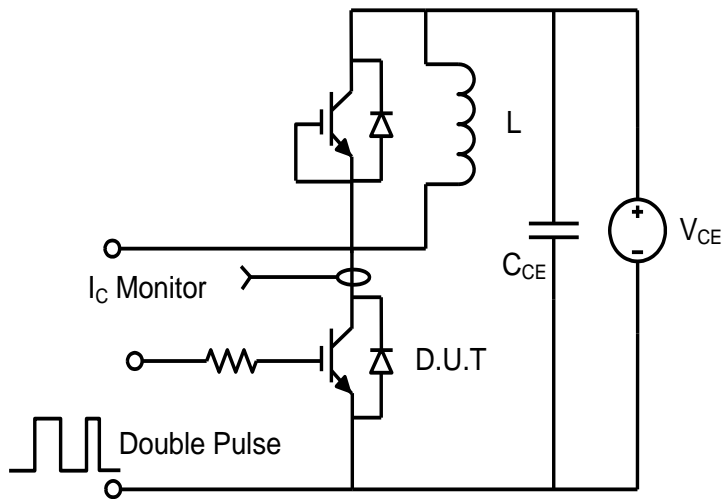

Package Outlines

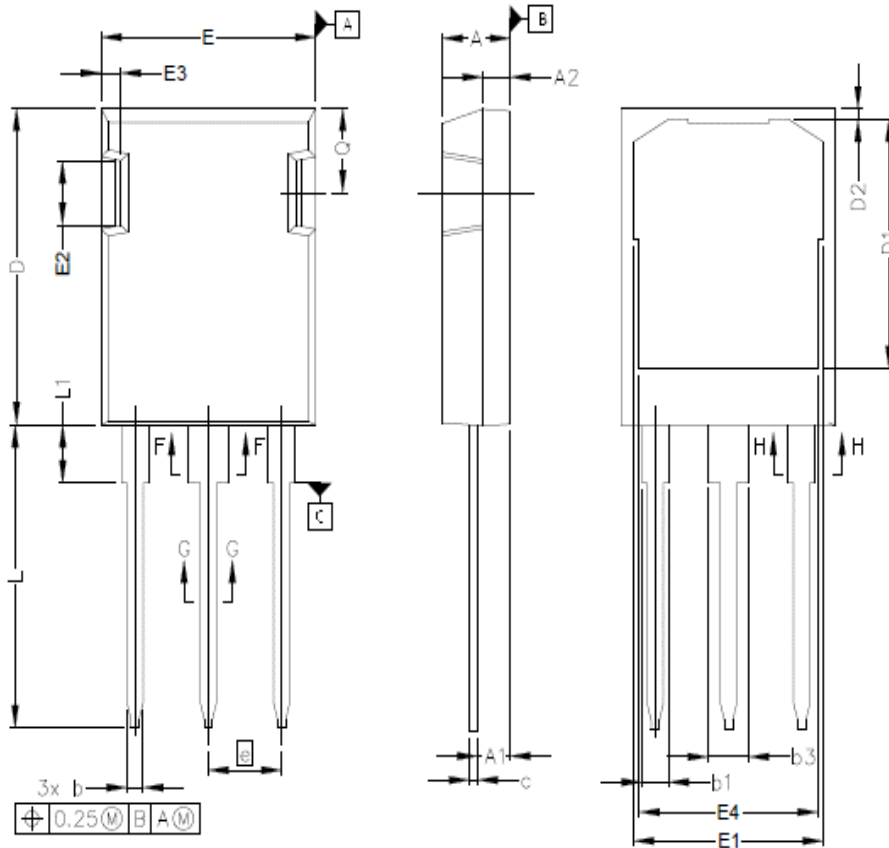

SYMBOL	MIN	MAX
A	4.83	5.21
A1	2.29	2.54
A2	1.91	2.16
b'	1.07	1.28
b	1.07	1.33
b1	1.91	2.41
b2	1.91	2.16
b3	2.87	3.38
b4	2.87	3.13
c'	0.55	0.65
c	0.55	0.68
D	20.80	21.10
D1	16.25	17.65
D2	0.50	0.80
E	15.75	16.13
E1	13.10	14.15
E2	3.68	5.10
E3	1.00	1.90
E4	12.38	13.43
e	5.44 BSC	
N	3	
L	19.81	20.32
L1	3.70	4.00
Q	5.49	6.00

---

## Marking Information



Note:

BK2A075YHH = Product Name Code

XXXXXXX = Date code

Contact ALKAIDSEMI sales for detail information

---

## Revision History

Revision	Release Date	Remark
Rev.1.3	2023/9/7	

## Disclaimer

The information given in this document describes the independent performance of the product, but similar performance is not guaranteed under other working conditions, and cannot be guaranteed when installed with other products or equipment. To achieve the required performance of the product in actual scenarios, the customer should conduct a complete application test to assess the functionality of the product.

Alkaidsemi assumes no responsibility for equipment failures result from using products at values that exceed the ratings, operating conditions, or other parameters listed in the product specifications.

The product described in this specification is not applicable for aerospace or other applications which requires high reliability. Customers using or selling these products for use in medical, life-saving, or life-sustaining applications do so at their own risk and agree to fully indemnify.

Due to product or technical improvements, the information described or contained herein may be changed without prior notice.